

ANDHRA PRADESH EDUCATION & WELFARE
INFRASTRUCTURE DEVELOPMENT CORPORATION

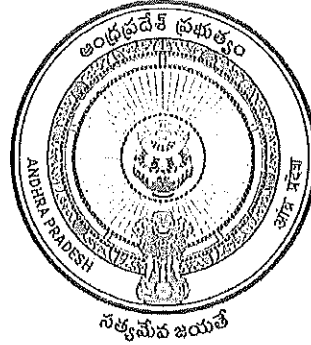

AGREEMENT

Name of the work :

Procurement of Powder Coated Galvanized Steel Doors (Frames with Shutters) to the Government Schools (Educational Institutions) of Srikakulam, Vizianagaram and Visakhapatnam Districts as Package-I in Andhra Pradesh

Estimate Cost:

Rs. 51.08 Crores

Name of the Contractor:

SHAKTI HORMANN PRIVATE LIMITED,
H.No.2-67/1, Survey, No.198, Gagillapur,
Gandimasamma Dundigal mandal,
Medchal Malkajgiri District,
Hyderabad-500043,

O/o THE MANAGING DIRECTOR,
APEWIDC, Vaddeswaram (V) Tadepally (M), Guntur

Bill of Quantities

Schedule-A

Sl. No	Qty (in Sqm)	Description of Item	Rate per Sqm	Unit per	Amount Rs
1	7200	<p>Supply & Fixing of Door of size of 1200 mm x 2100 mm (Single shutter) Powder Coated Galvanized Steel doors, frames & shutters made of Skin pass galvanized Iron sheet conforming to Base Steel Mild Steel as per IS 513 "D" Quality, Galvanized as per IS 277 with powder coating of thickness 60-65 Microns as per IS 13871 and IS 16074, Door frame with 1.2mm thick Skin pass Galvanized Iron sheet formed to single rebate profile of size 100 mm X 58 mm with 20 mm minimum width Architrave extension flushing the front wall and Door frame filled with in-fill Polyurethane foam.</p> <p>The door frame shall be provided with hinge jamb, lock jamb, head and steel base ties at the bottom of the door frames. The door frame shall be provided with 6 Holdfasts (fixing lugs) with split end tail, the head of the hold fast (fixing lug) 100 mm x25mmx1.25mm and tail shall be 200mmx40mmx1.25mm or 12 Nos Metal Anchors per frame of size 10 mm dia and of length of 90 mm to 120 mm.</p> <p>The door frame shall be provided with Mortar guard sheet Galvanized plain skin pass iron sheet 1.20 mm to 1.25 mm thick shall be welded to the frame at the head of the frame having tower bolt holes. It shall also be welded to the frame behind the hinges, mortise locks and latches slots, aldorp and sliding bolts and tower bolt holes etc.</p> <p>"Nadu-Nedu 2021" Logo shall be embossed and contrast painted on the top of the door frame in the right corner, the size of logo shall be such that it is clearly visible.</p> <p>The door frames shall be provided with suitable Lock Strike Plate, Shock Absorbers, Mortar Guards etc., as per IS 4351 (2008)</p> <p>Door frame Hinge support system shall be provided with Galvanized plain skin pass iron sheet of size 120mmx 30mmx6mm welded inside the door frame or 3mm stiffener plate of HR sheet or CR sheet with extended threads of 6 mm by pin forging and hinge screw as per IS 4351 (2003) shall be</p>	12,460.00	Sqm	8,97,12,000.00

Firm

[Handwritten Signature]

22

[Handwritten notes]
 14/8/2021
 4/11/18
 2021

[Handwritten Signature]
 Managing Director,
 APEWIDC, Vijayawada

provided, the stiffener plate followed by hot dip galvanizer and projection welding, welded inside the door frame with Mortar Guard with 1.2 mm to 1.25 mm thick Galvanized plain skin pass iron sheet the Mortar Guard is of size 230mmx40mmx20mm. The Mortar Guard shall be welded from inside into each hinge.

The Door Shutters **shall be made of 0.80 mm thick Skin pass Galvanized Iron Sheet (Confirming to IS 513 (2008), IS 277 (2003) IS 16074: 2013 (Reaffirmed 2018)), formed and shall be of 46 mm thick fully flush, double skin door shell with Lock Seam joints at stile edges, fitted with in-fill of Honeycomb Kraft Paper and coated with polyester powders of Pure polyester/ epoxy polyester or polyurethane powder for powder coating of thickness 60 – 65 microns or finished with Thermosetting Polyurethane paint of Aliphatic Grade providing high levels of scratch resistance and durability, as per IS 4351 (2003), and IS 13871. The shutter provided with 4 Numbers Stainless Steel Ball Bearing Butt Hinges 3 mm thick fixed flush to the frame and shutter, (Hinges Profile 102x76x3mm thick).**

In-fill of Door shutter Honeycomb Kraft Paper:-

In-fill of Door shutter Honeycomb Kraft Paper shall be of 16 mm cell size, 140 gsm, Core thickness 44.5 mm, Humidity of 6 to 10 percent and compression strength 150/200 kpa at 23°C and 130 °C respectively. The product shall confirm to EMPHA and ISO standards. The skin panels of the door and Honeycomb Kraft Paper shall be bonded with GLUE by automated GLUE spraying line with hot pressed rollers. The glue shall comply A2/IMO certified.

The stiffeners of Skin pass Galvanized Iron Sheet of specified thickness and sufficient width and length shall be provided inside the shutter at suitable places to fix fittings and fixtures, such as, locks, Mortise locks, latches, door handles, steel hook handles, mortise dead locks, aldop, tower bolt, sliding bolt, door stopper, door closer, etc. The provision shall be made to fix mortise lock as instructed by Authorities. The slots and holes shall be pierced in to the door shutter and necessary fixing arrangement shall be provided shall be welded to the pressed angle from the inner side of the shutter.

Stiffeners for Hinge : Stiffener of Skin pass Galvanized Iron Sheet of 3 mm thick shall be welded to the pressed angle from inner side of the shutter. The combined pressed angle (of 1.60

Firm



23

Handwritten notes: 7/12/21 and 4/12/21

Handwritten signature: Ch. Rajemeerreddy
Managing Director,
APEWIDC, Vijayawada

mm thick of Skin pass Galvanized Iron Sheet) and Skin pass Galvanized Iron Sheet of 3 mm thick shall be threaded to the required size of machine screw (M6 × 20 CSK) conforming to IS 1365, or **3mm stiffener plate of HR sheet or CR sheet with extended threads of 6 mm by pin forging and hinge screw as per IS 4351 (2003) shall be provided, the stiffener plate followed by hot dip galvanizer and projection welding, 2.2/1.8 mm joggling depth on a 3 mm hinge plate.**

Stiffeners for fittings and fixtures, such as locks, Mortise locks, latches, door handles, steel hook handles, mortise dead locks, aldrop, tower bolt, sliding bolt, door stopper, door closer, etc., Stiffener of pressed 'C' channels and Skin pass Galvanized Iron Sheet of thickness 1.60 mm and of sufficient width and length or **1.2 mm thick (Skin pass Galvanized Iron Sheet) rectangular box cross sectional stiffener between the two skins of the door shutter (to the full inner thickness of the door shutter) of required width and height as per the iron mongery**, shall be provided inside the shutter at suitable places to fix fittings and fixtures, such as, aldrop, towerbolt, sliding bolt, door stopper, door closer, etc.,

The slots and holes shall be pierced in to the door shutter and necessary fixing arrangement shall be provided.

Following Joinery and Fixtures shall be fixed

(A) Stainless Steel 304 Aldrop heavy duty 300 mm long and 16 mm dia rod.

(B)) Stainless Steel 304 Lever handles (pair) 200 mm length and 16 mm dia rod.

(C) 250 mm dia long MS Powder Coated Tower bolt (heavy duty) rod of 10 mm dia (IS 204)

Fixing the Doors and shutters at Schools including with all specified hardware, including cost & conveyance of all materials and all labour charges like erecting and fixing at schools as per standard specifications including Loading & unloading and stocking charges, to school site inclusive of GST and all other Taxes etc. as applicable from time to time, and all other incidental charges etc, complete for finished item of work to the Government schools in the state of Andhra Pradesh.

Firm

[Handwritten signature]



24

[Handwritten signature]
Managing Director,
APEWIDC, Vijayawada

The item shall carry a warranty period of 5 (Five) years from the date of completion.



Profile of Pressed Steel Door Frame
All Dimensions in mm

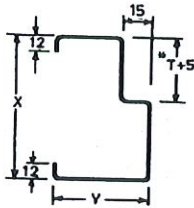

Arrangement at base of Door Frame

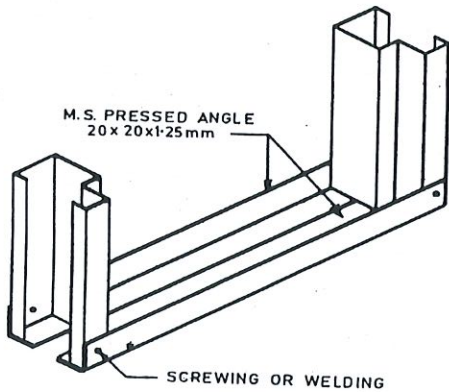

Holdfast required for Masonry

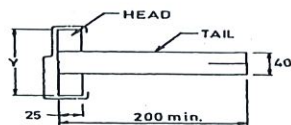

4A Fixing Lug (Holdfast)
(Required for Masonry)

Metal Anchors
of size 10 mm
dia and of
length of 90
mm to 120
mm



Firm



Handwritten notes: 17/11/2014, 14/12/14, 4/48/21

Handwritten signature: Ch. Rajeswarreddy
Managing Director,
APEWIDC, Vijayawada

Fixing Galvanized plain skin pass iron sheet
Plate Stiffner and Mortar Guard in door frame for

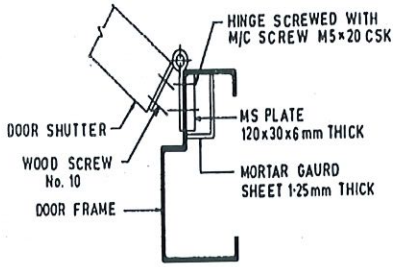

Hinge

Lock Strike Plate

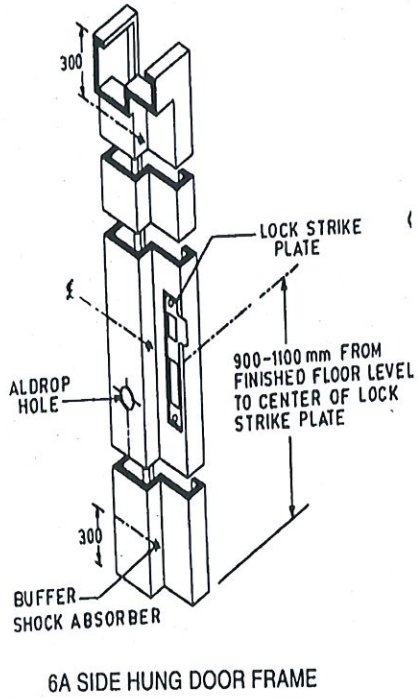

Lock Seam Joints 1

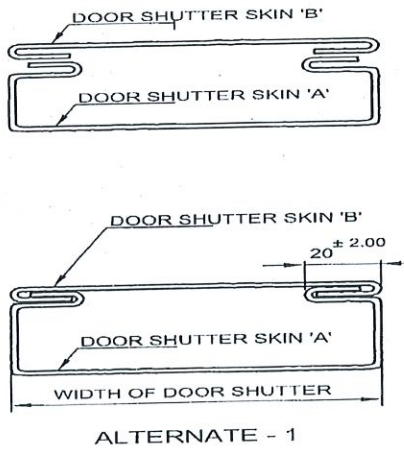

Firm

[Handwritten signature]



[Handwritten notes: 14/11/18, 4/11/18, 21]

[Handwritten signature: Ch. Rajenwarreddy]
Managing Director,
APEWIDC, Vijayawada

Honey Comb Kraft Paper Core in Door Shutter

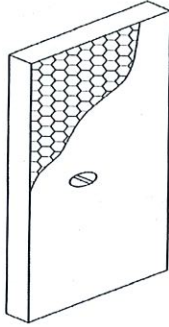

HONEY COMB
KRAFT PAPER CORE

Door Shutter Construction (Stiffeners, etc.,)

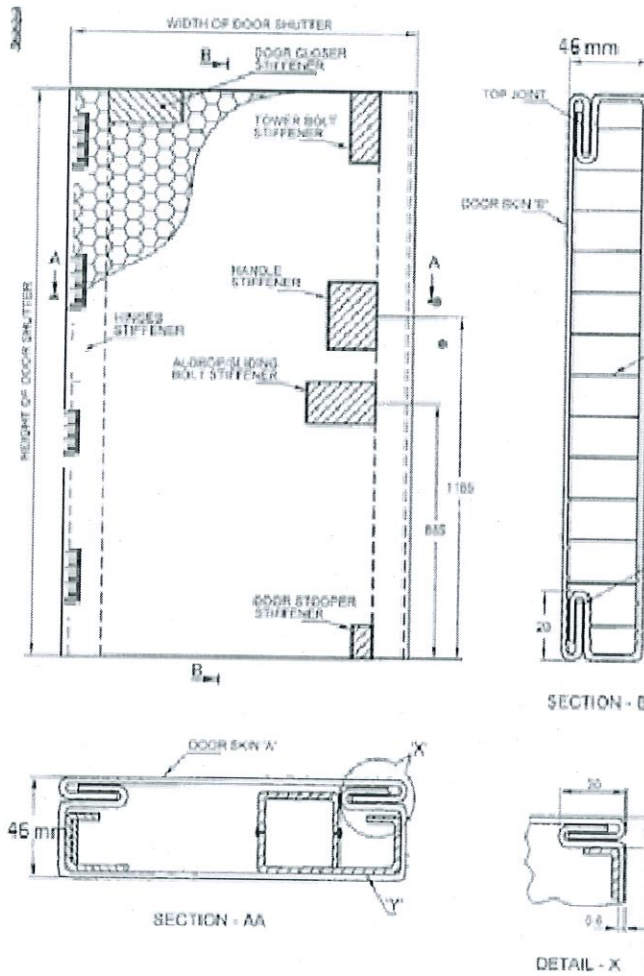

Firm



Handwritten notes in blue ink: '14/12/21' and '4/14/21'.

Ch. Rajeswararaj
Managing Director,
APEWIDC, Vijayawada

Hinges
Handles (pair)

Lever

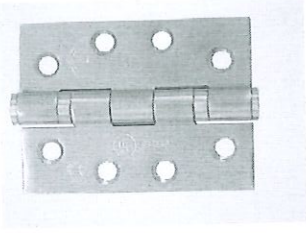

Stainless Steel 304 Heavy Duty Aldrop

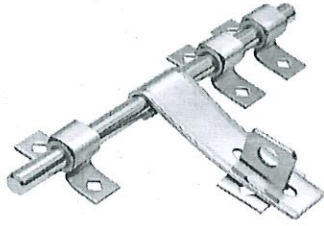

Powder Coated (MS) Tower Bolt

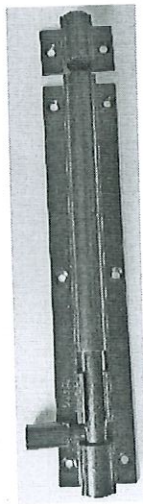

Firm



14/10/24 4/14/18 21

Ch. Rajenwarreddy
Managing Director,
APEWIDC, Vijayawada

Sl. No	Qty (in Sqm)	Description of Item	Rate per Sqm	Unit per	Amount Rs
2	21600	<p>Supply & Fixing of Toilet Door of size 750 mm x 2100 mm (Single shutter) Powder Coated Galvanized Steel doors, frames & shutters made of Skin pass galvanized Iron sheet conforming to Base Steel Mild Steel as per IS 513 "D" Quality, Galvanized as per IS 277 with powder coating of thickness 60-65 Microns as per IS 13871 and IS 16074, Door frame with 1.2mm thick Skin pass Galvanized Iron sheet formed to single rebate profile of size 100 mm X 58 mm with 20 mm minimum width Architrave extension flushing the front wall and Door frame filled with in-fill Polyurethane foam.</p> <p>The door frame shall be provided with hinge jamb, lock jamb, head steel tie of the door frames. The door frame shall be provided with 6 Holdfasts (fixing lugs) with split end tail, the head of the hold fast (fixing lug) 100 mm x25mmx1.25mm and tail shall be 200mmx40mmx1.25mm or 12 Nos Metal Anchors per frame of size 10 mm dia and of length of 90 mm to 120 mm.</p> <p>The doors shall be provided with Mortar guard sheet Galvanized plain skin pass iron sheet 1.20 mm to 1.25 mm thick shall be welded to the frame at the head of the frame having tower bolt holes. It shall also be welded to the frame behind the hinges, mortize locks and latches slots, aldrop and sliding bolts and tower bolt holes etc.</p> <p>"Nadu-Nedu 2021" Logo shall be embossed and contrast painted on the top of the door frame in the right corner, the size of logo shall be such that it is clearly visible.</p> <p>The door frames shall be provided with suitable Lock Strike Plate, Shock Absorbers, Mortar Guards etc., as per IS 4351 (2008)</p> <p>Door frame Hinge support system shall be provided with Galvanized plain skin pass iron sheet of size 120mmx 30mmx6mm welded inside the door frame or 3mm stiffener plate of HR sheet or CR sheet with extended threads of 6 mm by pin forging and hinge screw as per IS 4351 (2003) shall be provided, the stiffener plate followed by hot dip galvanizer and</p>	12,960.00	Sqm	27,99,36,000.00

Firm



29

Handwritten notes: 14/12/21, 14/18, 21

Handwritten signature: Ch. Rajeswarreddy
 Managing Director,
 APEWIDC, Vijayawada

projection welding, welded inside the door frame with Mortar Guard with 1.2 mm to 1.25 mm thick Galvanized plain skin pass iron sheet the Mortar Guard is of size 230mmx40mmx20mm. The Mortar Guard shall be welded from inside into each hinge.

The Door Shutters **shall be made of** 0.80 mm thick Skin pass Galvanized Iron Sheet (Confirming to IS 513 (2008), IS 277 (2003) IS 16074: 2013 (Reaffirmed 2018)), **formed and shall be of 46 mm thick fully flush, double skin door shell with Lock Seam joints at stile edges, fitted with in-fill of Honeycomb Kraft Paper and coated with polyester powders of Pure polyester/ epoxy polyester or polyurethane powder for powder coating of thickness 60 – 65 microns or finished with Thermosetting Polyurethane paint of Aliphatic Grade providing high levels of scratch resistance and durability, as per IS 4351 (2003), and IS 13871.** The shutter provided with **4 Numbers Stainless Steel Ball Bearing Butt Hinges** 3 mm thick fixed flush to the frame and shutter, (**Hinges Profile 102x76x3mm thick**).
The door shutter shall have a bottom gap of 150 mm above the floor level.

In-fill of Door shutter Honeycomb Kraft Paper:-

In-fill of Door shutter Honeycomb Kraft Paper shall be of 16 mm cell size, 140 gsm, Core thickness 44.5 mm, Humidity of 6 to 10 percent and compression strength 150/200 kpa at 23°C and 130 °C respectively. The product shall confirm to EMPHA and ISO standards. The skin panels of the door and Honeycomb Kraft Paper shall be bonded with GLUE by automated GLUE spraying line with hot pressed rollers. The glue shall comply A2/IMO certified.

The stiffeners of Skin pass Galvanized Iron Sheet of specified thickness and sufficient width and length shall be provided inside the shutter at suitable places to fix fittings and fixtures, such as, locks, Mortise locks, latches, door "D" handles, steel hook handles, mortise dead locks, aldrop, tower bolt, sliding bolt, door stopper, door closer, etc. The provision shall be made to fix mortise lock as instructed by Authorities. The slots and holes shall be pierced in to the door shutter and necessary fixing arrangement shall be provided shall be welded to the pressed angle from the inner side of the

Firm



30

14/8/18
21

Ch. Rajeswarreddy
Managing Director,
APEWIDC, Vijayawada

shutter.

Stiffeners for Hinge : Stiffener of Skin pass Galvanized Iron Sheet of 3 mm thick shall be welded to the pressed angle from inner side of the shutter. The combined pressed angle (of 1.60 mm thick of Skin pass Galvanized Iron Sheet) and Skin pass Galvanized Iron Sheet of 3 mm thick shall be threaded to the required size of machine screw (M6 x 20 CSK) conforming to IS 1365, or **3mm stiffener plate of HR sheet or CR sheet with extended threads of 6 mm by pin forging and hinge screw as per IS 4351 (2003) shall be provided, the stiffener plate followed by hot dip galvanizer and projection welding, 2.2/1.8 mm joggling depth on a 3 mm hinge plate.**

Stiffeners for fittings and fixtures, such as locks, Mortise locks, latches, door "D" handles, steel hook handles, mortise dead locks, aldrop, tower bolt, sliding bolt, door stopper, door closer, etc.,

Stiffener of pressed 'C' channels and Skin pass Galvanized Iron Sheet of thickness 1.60 mm and of sufficient width and length or **1.2 mm thick (Skin pass Galvanized Iron Sheet) rectangular box cross sectional stiffener between the two skins of the door shutter (to the full inner thickness of the door shutter) of required width and height as per the iron mongery,** shall be provided inside the shutter at suitable places to fix fittings and fixtures, such as, aldrop, tower bolt, sliding bolt, door stopper, door closer, etc.,

The slots and holes shall be pierced in to the door shutter and necessary fixing arrangement shall be provided.

Following Joinery and Fixtures shall be fixed

(A) Stainless Steel (SS 304) Heavy Duty Al Drop 200 mm long (16 mm dia) - 1 No.

(B) Two sides and bottom of door shutter "U" shaped Stainless Steel Mop Plates Size of 150 mm and 0.60mm thickness each side, fixed on all faces of the door Shutter to full shutter width, to edge faces and covering the bottom also.

(C) SS Horizontal "D" Type Handle 200 mmx16 mm Dia. - 1 Pair

(D) Powder Coated Horizontal Tower Bolt of length 200 mm and 10 mm dia fixed at

Firm

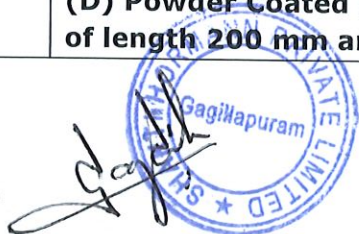

31

Handwritten notes: 14/11/14, 9/14/18, 21

Handwritten signature: Ch. Rajemareddy
Managing Director,
APEWIDC, Vijayawada

height of 1000 mm from bottom.

**(E) Stainless Steel Hook hanger
(minimum 2 hooks)**

The doors of a toilet complex in a particular campus shall be of different colors.

Fixing the Doors and shutters at Schools including with all specified hardware, including cost & conveyance of all materials and all labour charges like erecting and fixing at schools as per standard specifications including Loading & unloading and stocking charges, to school site inclusive of GST and all other Taxes etc. as applicable from time to time, and all other incidental charges etc, complete for finished item of work to the Government schools in the state of Andhra Pradesh.



The item shall carry a warranty period of 5 (Five) years from the date of completion.

Profile of Pressed Steel Door Frame

T is the Thickness of the Shutter.

All Dimensions in mm

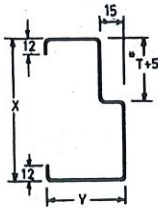

Holdfast required for Masonary

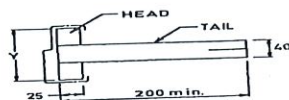

4A Fixing Lug (Holdfast)
(Required for Masonry)

Metal Anchors of size 10 mm dia and of length of 90 mm to 120 mm



Firm



32

Handwritten notes: '14/12/18' and '21' with a signature.

Handwritten signature: *Ch. Rajenwarreddy*
Managing Director,
APEWIDC, Vijayawada

Fixing Galvanized plain skin pass iron sheet Plate Stiffner and Mortar Guard in door frame for Hinge

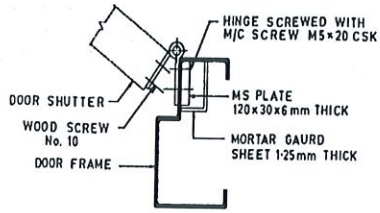

Lock Strike Plate

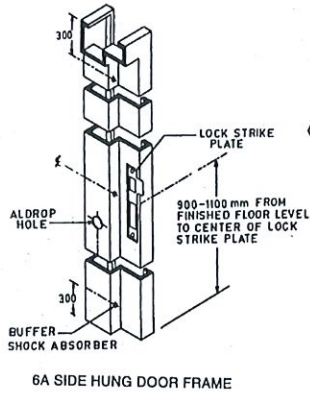

Plumbing nails

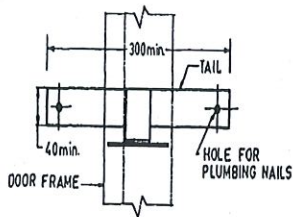

Lock Seam Joints 1

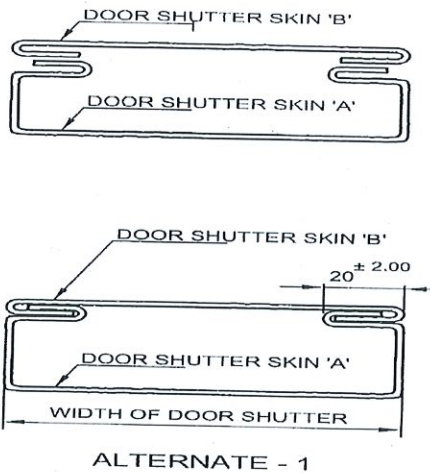

Firm



M/18/14 9/14/18 21

Ch. Rajeswarreddy
 Managing Director,
 APEWIDC, Vijayawada

Honey Comb Kraft Paper Core in door shutter

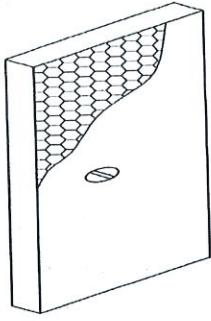

HONEY COMB
KRAFT PAPER CORE

Door Shutter Construction (Stiffeners, etc.,)

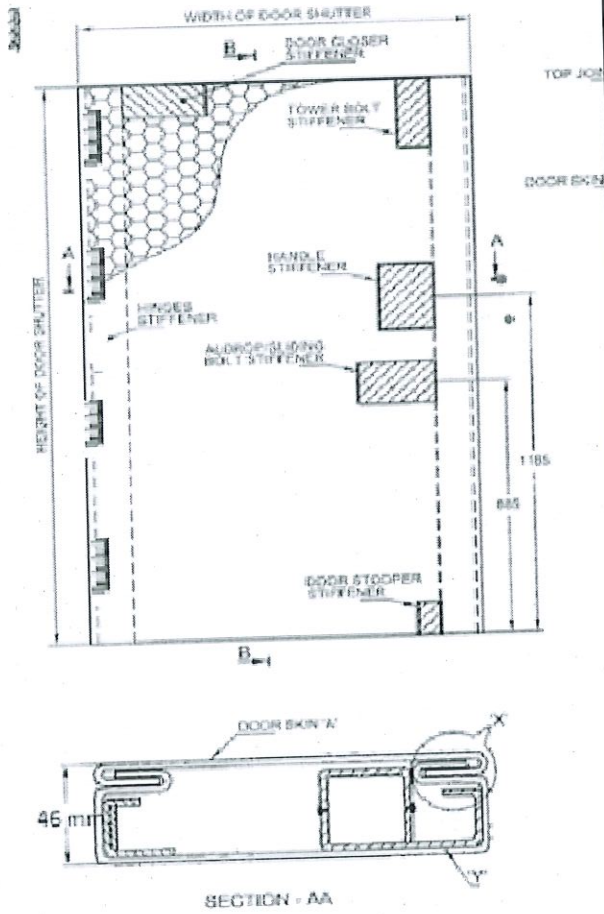

Firm

Signature



Handwritten notes: 14/8/24, 9/14/18, 22

Signature
Managing Director,
APEWIDC, Vijayawada

Hinges

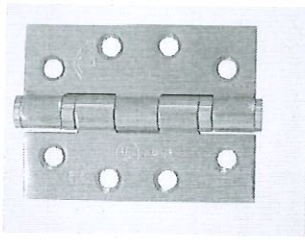

D Handle

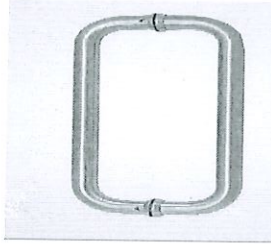

Stainless Steel Mop Plate

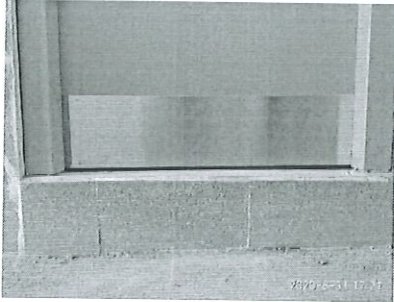

Heavy Duty Aldrop

Stainless Steel

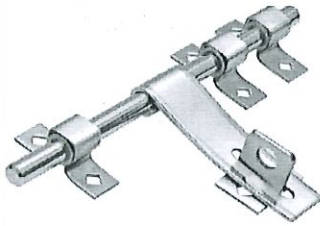

Stainless Steel Hook Hanger



Power coated (MS) Tower Bolt

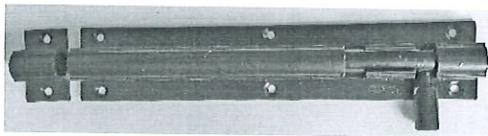

Firm



14/12/21 4/11/21

Ch. Rajeswararaj Reddy
Managing Director,
APEWIDC, Vijayawada

Sl. No.	Qty (in Sqm)	Description of Item	Rate per Sqm	Unit per	Amount Rs
3	9600	<p>Supply & Fixing of (Differently abled) Door of size 1200 mm x 2100 mm (Single shutter) Powder Coated Galvanized Steel doors, frames & shutters made of Skin pass galvanized Iron sheet conforming to Base Steel Mild Steel as per IS 513 "D" Quality, Galvanized as per IS 277 with powder coating of thickness 60-65 Microns as per IS 13871 and IS 16074, Door frame with 1.2mm thick Skin pass Galvanized Iron sheet formed to single rebate profile of size 100 mm X 58 mm with 20 mm minimum width Architrave extension flushing the front wall and Door frame filled with in-fill Polyurethane foam.</p> <p>The door frame shall be provided with hinge jamb, lock jamb, head steel tie of the door frames. The door frame shall be provided with 6 Holdfasts (fixing lugs) with split end tail, the head of the hold fast (fixing lug) 100 mm x25mmx1.25mm and tail shall be 200mmx40mmx1.25mm or 12 Nos Metal Anchors per frame of size 10 mm dia and of length of 90 mm to 120 mm.</p> <p>The doors shall be provided with Mortar guard sheet Galvanized plain skin pass iron sheet 1.20 mm to 1.25 mm thick shall be welded to the frame at the head of the frame having tower bolt holes. It shall also be welded to the frame behind the hinges, mortize locks and latches slots, aldop and sliding bolts and tower bolt holes etc.</p> <p>"Nadu-Nedu 2021" Logo shall be embossed and contrast painted on the top of the door frame in the right corner, the size of logo shall be such that it is clearly visible.</p> <p>The door frames shall be provided with suitable Lock Strike Plate, Shock Absorbers, Mortar Guards etc., as per IS 4351 (2008)</p> <p>Door frame Hinge support system shall be provided with Galvanized plain skin pass iron sheet of size 120mmx 30mmx6mm welded inside the door frame or 3mm stiffener plate of HR sheet or CR sheet with extended threads of 6 mm by pin forging and hinge screw as per IS 4351 (2003) shall be provided, the stiffener plate followed by hot dip galvanizer and projection welding, welded inside the door frame with Mortar Guard with 1.2 mm to 1.25 mm thick Galvanized plain skin pass iron sheet the Mortar Guard is of size 230mmx40mmx20mm. The Mortar Guard shall be welded from inside into each hinge.</p> <p>The Door Shutters shall be made of 0.80 mm thick Skin pass Galvanized Iron Sheet (Confirming to IS 513 (2008), IS 277 (2003) IS 16074: 2013 (Reaffirmed 2018)), formed and shall be of 46 mm thick fully</p>	12,737.00	Sqm	12,22,75,200

Firm



36

Managing Director,
APEWIDC, Vijayawada

flush, double skin door shell with **Lock Seam joints at stile edges**, fitted with in-fill of **Honeycomb Kraft Paper** and coated with **polyester powders of Pure polyester/ epoxy polyester or polyurethane powder for powder coating of thickness 60 – 65 microns or finished with Thermosetting Polyurethane paint of Aliphatic Grade providing high levels of scratch resistance and durability, as per IS 4351 (2003), and IS 13871.** The shutter provided with **4 Numbers Stainless Steel Ball Bearing Butt Hinges 3 mm thick fixed flush to the frame and shutter, (Hinges Profile 102x76x3mm thick).**

The door shutter shall have a bottom gap of 150 mm above the floor level.

In-fill of Door shutter Honeycomb Kraft Paper:-
In-fill of Door shutter Honeycomb Kraft Paper shall be of 16 mm cell size, 140 gsm, Core thickness 44.5 mm, Humidity of 6 to 10 percent and compression strength 150/200 kpa at 23°C and 130 °C respectively. The product shall confirm to EMPHA and ISO standards. The skin panels of the door and Honeycomb Kraft Paper shall be bonded with GLUE by automated GLUE spraying line with hot pressed rollers. The glue shall comply A2/IMO certified.

The stiffeners of Skin pass Galvanized Iron Sheet of specified thickness and sufficient width and length shall be provided inside the shutter at suitable places to fix fittings and fixtures, such as, locks, Mortise locks, latches, door "D" handles, steel hook handles, mortise dead locks, aldrop, tower bolt, sliding bolt, door stopper, door closer, etc. The provision shall be made to fix mortise lock as instructed by Authorities. The slots and holes shall be pierced in to the door shutter and necessary fixing arrangement shall be provided shall be welded to the pressed angle from the inner side of the shutter.

Stiffeners for Hinge : Stiffener of Skin pass Galvanized Iron Sheet of 3 mm thick shall be welded to the pressed angle from inner side of the shutter. The combined pressed angle (of 1.60 mm thick of Skin pass Galvanized Iron Sheet) and Skin pass Galvanized Iron Sheet of 3 mm thick shall be threaded to the required size of machine screw (**M6 × 20 CSK**) conforming to IS 1365, **or 3mm stiffener plate of HR sheet or CR sheet with extended threads of 6 mm by pin forging and hinge screw as per IS 4351 (2003) shall be provided, the stiffener plate followed by hot dip galvanizer and projection welding, 2.2/1.8 mm joggling depth on a 3 mm hinge plate.**

Stiffeners for fittings and fixtures, such as locks, Mortise locks, latches, door "D" handles, steel hook handles, mortise dead locks, aldrop, tower bolt, sliding bolt, door stopper, door closer, etc.,

Stiffener of pressed 'C' channels and Skin pass Galvanized Iron Sheet of thickness 1.60 mm and of sufficient width and length or **1.2 mm thick (Skin pass Galvanized Iron Sheet) rectangular box cross**

Firm



37

Handwritten notes: 14/8/24, 14/8/24

Handwritten signature: *Ch. Rajeswarreddy*
Managing Director,
APEWIDC, Vijayawada

sectional stiffener between the two skins of the door shutter (to the full inner thickness of the door shutter) of required width and height as per the iron mongery, shall be provided inside the shutter at suitable places to fix fittings and fixtures, such as, aldrop, towerbolt, sliding bolt, door stopper, door closer, etc,. The slots and holes shall be pierced in to the door shutter and necessary fixing arrangement shall be provided.
Following Joinery and Fixtures shall be fixed

(A) Stainless Steel (SS 304) Heavy Duty Al Drop 200 mm long (16 mm dia) – 1 No.

(B) Two sides and bottom of door shutter "U" shaped Stainless Steel Mop Plates Size of 150 mm and 0.60mm thickness each side, fixed on all faces of the door Shutter to full shutter width, to edge faces and covering the bottom also.

(C) SS Horizontal "D" Type Handle 200 mmx16 mm Dia. – 1 Pair

(D) Powder Coated Horizontal Tower Bolt of length 200 mm and 10 mm dia fixed at height of 1000 mm from bottom.

(E) Stainless Steel Hook hanger (minimum 2 hooks)

Fixing the Doors and shutters at Schools including with all specified hardware, including cost & conveyance of all materials and all labour charges like erecting and fixing at schools as per standard specifications including Loading & unloading and stocking charges, to school site inclusive of GST and all other Taxes etc. as applicable from time to time, and all other incidental charges etc, complete for finished item of work to the Government schools in the state of Andhra Pradesh



The item shall carry a warranty period of 5 (Five) years from the date of completion.

BMT-N.55

Firm



38

14/8/21 9/14/18
21

Ch. Rajenwarreddy
Managing Director,
APEWIDC, Vijayawada

Profile of Pressed Steel Door Frame
 T is the Thickness of the Shutter.
All Dimensions in mm

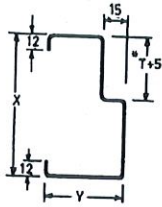

Holdfast required for Masonry

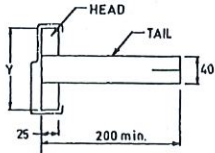

4A Fixing Lug (Holdfast)
 (Required for Masonry)

Metal Anchors of size 10 mm dia and of length of 90 mm to 120 mm



Fixing **Galvanized plain skin pass iron sheet** Plate Stiffner and Mortar Guard in door frame for Hinge

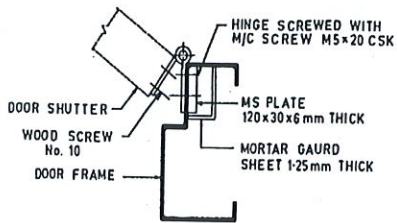

Lock Strike Plate

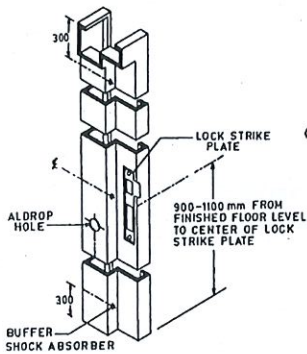

6A SIDE HUNG DOOR FRAME

Plumbing nails

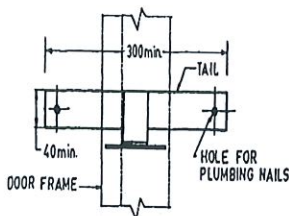

Firm



Handwritten notes: 14/12/14, 4/1/18, 21

Ch. Rajeswarreddy
 Managing Director,
 APEWIDC, Vijayawada

Lock Seam Joints 1

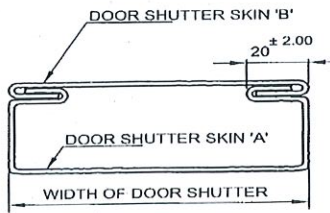
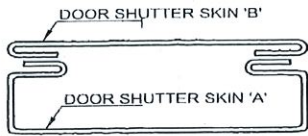

ALTERNATE - 1

Honey Comb Kraft Paper Core

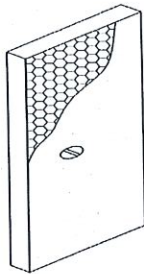

HONEY COMB
KRAFT PAPER CORE

Firm



14/8/21 4/14/8
21

Ch. Rajenwarreddy

Managing Director,
APEWIDC, Vijayawada

Door Shutter Construction (Stiffeners, etc.,)

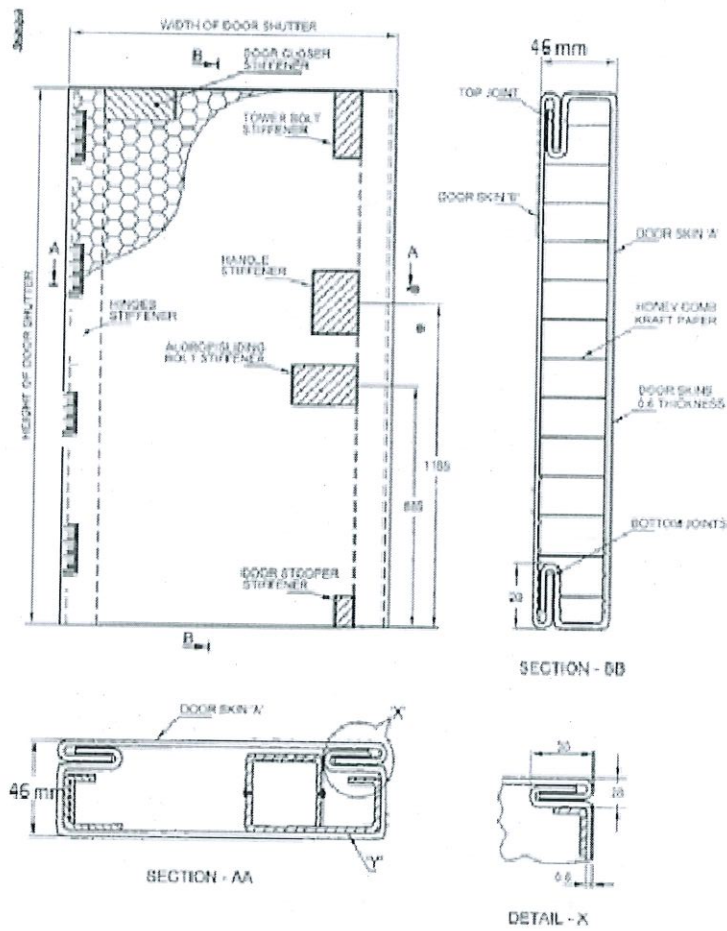

Firm



Handwritten notes and dates in blue ink, including "14/1/14" and "14/1/18".

Handwritten initials in blue ink.

Managing Director,
APEWIDC, Vijayawada

Hinges

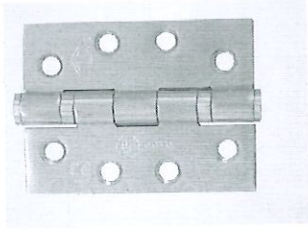

D Handle

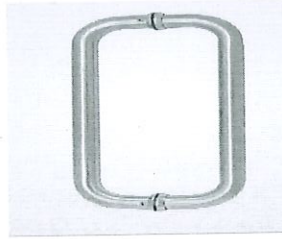

Stainless Steel Mop Plate

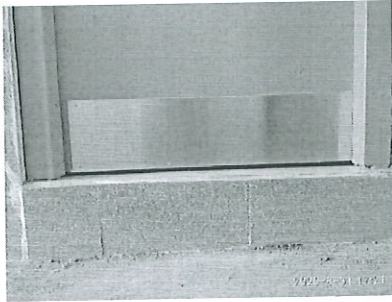

Stainless Steel Heavy Duty Aldrop

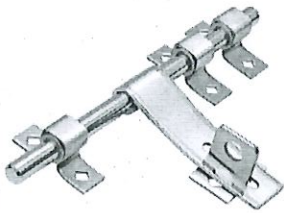

Stainless Steel Hook Hanger



Powder Coated (MS) Tower Bolt

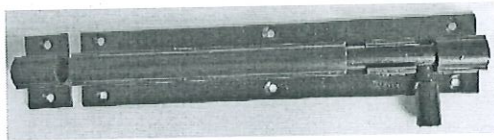

Firm



Handwritten notes in blue ink: '14/10/21' and '4/4/8 21'.



Sl.No	Qty (in Sqm)	Description of Item	Rate per Sqm	Unit per	Amount
4	2400	<p>Supply & Fixing of Door of customized size from 1.6 Sq Mts to 2.52 Sq Mts of Door area (Single shutter) Powder Coated Galvanized Steel doors, frames & shutters made of Skin pass galvanized Iron sheet conforming to Base Steel Mild Steel as per IS 513 "D" Quality, Galvanized as per IS 277 with powder coating of thickness 60-65 Microns as per IS 13871 and IS 16074, Door frame with 1.2mm thick Skin pass Galvanized Iron sheet formed to single rebate profile of size 100 mm X 58 mm with 20 mm minimum width Architrave extension flushing the front wall and Door frame filled with in-fill Polyurethane foam.</p> <p>The door frame shall be provided with hinge jamb, lock jamb, head and steel base ties at the bottom of the door frames. The door frame shall be provided with 6 Holdfasts (fixing lugs) with split end tail, the head of the hold fast (fixing lug) 100 mm x25mmx1.25mm and tail shall be 200mmx40mmx1.25mm or 12 Nos Metal Anchors per frame of size 10 mm dia and of length of 90 mm to 120 mm.</p> <p>The door frame shall be provided with Mortar guard sheet Galvanized plain skin pass iron sheet 1.20 mm to 1.25 mm thick shall be welded to the frame at the head of the frame having tower bolt holes. It shall also be welded to the frame behind the hinges, mortise locks and latches slots, adrop and sliding bolts and tower bolt holes etc.</p> <p>"Nadu-Nedu 2021" Logo shall be embossed and contrast painted on the top of the door frame in the right corner, the size of logo shall be such that it is clearly visible.</p> <p>The door frames shall be provided with suitable Lock Strike Plate, Shock Absorbers, Mortar Guards etc., as per IS 4351 (2008)</p> <p>Door frame Hinge support system shall be provided with Galvanized plain skin pass iron sheet of size 120mmx 30mmx6mm welded inside the door frame or 3mm stiffener plate of HR sheet or CR sheet with extended threads of 6 mm by pin forging and hinge screw as per IS 4351 (2003) shall be provided, the stiffener plate followed by hot dip galvanizer and projection welding, welded inside the door frame with Mortar Guard with 1.2 mm to 1.25 mm thick Galvanized plain skin pass iron sheet the Mortar Guard is of size 230mmx40mmx20mm. The Mortar Guard shall be welded from inside into each hinge.</p> <p>The Door Shutters shall be made of 0.80 mm thick Skin pass Galvanized Iron Sheet (Confirming to IS 513 (2008), IS 277 (2003) IS 16074: 2013 (Reaffirmed 2018)), formed and shall be of 46 mm thick fully flush, double skin door</p>	12,529.00	Sqm	3,00,69,348

Firm

43

Handwritten signature and date 14/10/21 with number 9148/21.

Handwritten signature of Ch. Rameswarareddy, Managing Director, APEWIDC, Vijayawada.

shell with **Lock Seam joints at stile edges**, fitted with in-fill of **Honeycomb Kraft Paper** and coated with **polyester powders of Pure polyester/ epoxy polyester or polyurethane powder for powder coating of thickness 60 – 65 microns or finished with Thermosetting Polyurethane paint of Aliphatic Grade providing high levels of scratch resistance and durability, as per IS 4351 (2003), and IS 13871**. The shutter provided with **4 Numbers Stainless Steel Ball Bearing Butt Hinges 3 mm thick fixed flush to the frame and shutter, (Hinges Profile 102x76x3mm thick)**.

In-fill of Door shutter Honeycomb Kraft Paper:-

In-fill of Door shutter Honeycomb Kraft Paper shall be of 16 mm cell size, 140 gsm, Core thickness 44.5 mm, Humidity of 6 to 10 percent and compression strength 150/200 kpa at 23°C and 130 °C respectively. The product shall confirm to EMPHA and ISO standards. The skin panels of the door and Honeycomb Kraft Paper shall be bonded with GLUE by automated GLUE spraying line with hot pressed rollers. The glue shall comply A2/IMO certified.

The stiffeners of Skin pass Galvanized Iron Sheet of specified thickness and sufficient width and length shall be provided inside the shutter at suitable places to fix fittings and fixtures, such as, locks, Mortise locks, laches, door "D" handles, steel hook handles, mortise dead locks, aldrop, tower bolt, sliding bolt, door stopper, door closer, etc. The provision shall be made to fix mortise lock as instructed by Authorities. The slots and holes shall be pierced in to the door shutter and necessary fixing arrangement shall be provided shall be welded to the pressed angle from the inner side of the shutter.

Stiffeners for Hinge : Stiffener of Skin pass Galvanized Iron Sheet of 3 mm thick shall be welded to the pressed angle from inner side of the shutter. The combined pressed angle (of 1.60 mm thick of Skin pass Galvanized Iron Sheet) and Skin pass Galvanized Iron Sheet of 3 mm thick shall be threaded to the required size of machine screw (**M6 × 20 CSK**) conforming to IS 1365, **or 3mm stiffener plate of HR sheet or CR sheet with extended threads of 6 mm by pin forging and hinge screw as per IS 4351 (2003) shall be provided, the stiffener plate followed by hot dip galvanizer and projection welding, 2.2/1.8 mm joggling depth on a 3 mm hinge plate.**

Stiffeners for fittings and fixtures, such as locks, Mortise locks, laches, door "D" handles, steel hook handles, mortise dead locks, aldrop, tower bolt, sliding bolt, door stopper, door closer, etc.,

Stiffener of pressed 'C' channels and Skin pass Galvanized Iron Sheet of thickness 1.60 mm and of sufficient width and length or **1.2 mm thick (Skin pass Galvanized Iron Sheet) rectangular box cross sectional stiffener between the two skins of the door shutter (to the full inner thickness of the door shutter) of required width and height as per the iron mongery, shall be provided inside the shutter at suitable places to fix fittings and**

Firm



44

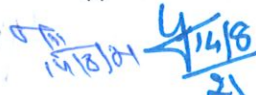

Managing Director,
APEWIDC, Vijayawada

fixtures, such as, aldrop, towerbolt, sliding bolt, door stopper, door closer, etc.,

The slots and holes shall be pierced in to the door shutter and necessary fixing arrangement shall be provided.

Following Joinery and Fixtures shall be fixed

(A) Stainless Steel 304 Aldrop heavy duty 300 mm long and 16 mm dia rod.

(B)) Stainless Steel 304 Lever handles (pair) 200 mm length and 16 mm dia rod.

(C) 250 mm dia long MS Powder Coated Tower bolt (heavy duty) rod of 10 mm dia (IS 204)

Fixing the Doors and shutters at Schools including with all specified hardware, including cost & conveyance of all materials and all labour charges like erecting and fixing at schools as per standard specifications including Loading & unloading and stocking charges, to school site inclusive of GST and all other Taxes etc. as applicable from time to time, and all other incidental charges etc, complete for finished item of work to the Government schools in the state of Andhra Pradesh.

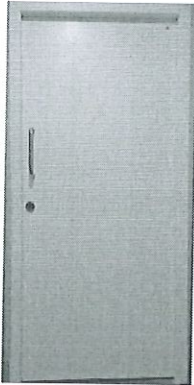

The item shall carry a warranty period of 5 (Five) years from the date of completion.

Profile of Pressed Steel Door Frame
All Dimensions in mm

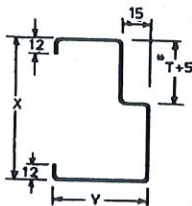

Firm



45

Handwritten notes and dates: '14/8/21' and '14/8/21'.

Handwritten signature: *Ch. Rajenarreddy*
Managing Director,
APEWIDC, Vijayawada

Arrangement at base of Door Frame

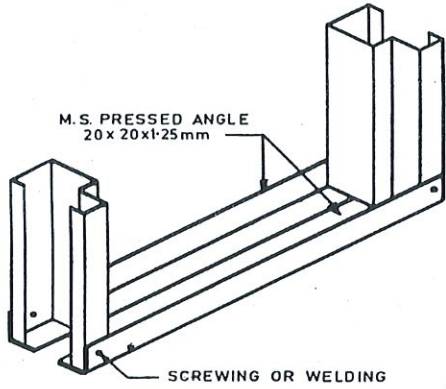

Holdfast required for Masonry

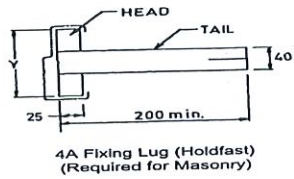

Metal Anchors of size 10 mm dia and of length of 90 mm to 120 mm



Fixing **Galvanized plain skin pass iron sheet** Plate Stiffner and Mortar Guard in door frame for Hinge

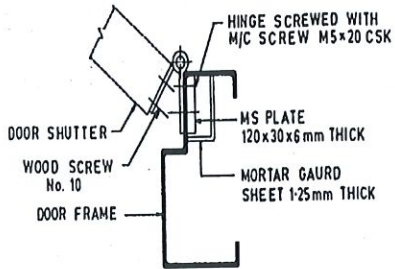

Firm



Handwritten notes and dates: '7/11/21', '11/18/21', and '7/14/21'.

Signature of Ch. Rajenwarreddy
 Managing Director,
 APEWIDC, Vijayawada

Lock Strike Plate

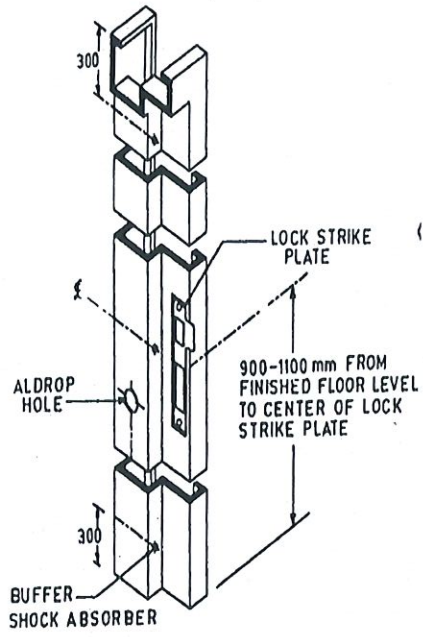

6A SIDE HUNG DOOR FRAME

Lock Seam Joints 1

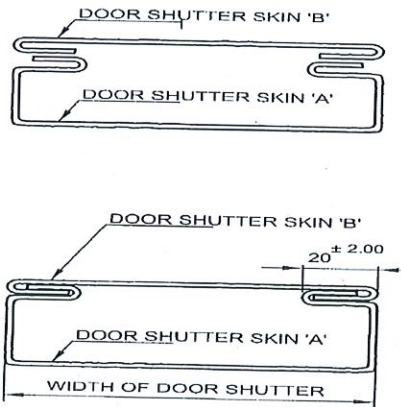

ALTERNATE - 1

Honey Comb Kraft Paper Core in Door Shutter

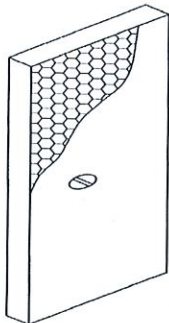

HONEY COMB KRAFT PAPER CORE

Firm



Handwritten notes and dates: '14/8/21' and '14/8/21'.

Handwritten signature: *Ch. Rajeswarareddy*
 Managing Director,
 APEWIDC, Vijayawada

Door Shutter Construction (Stiffners, etc.,)

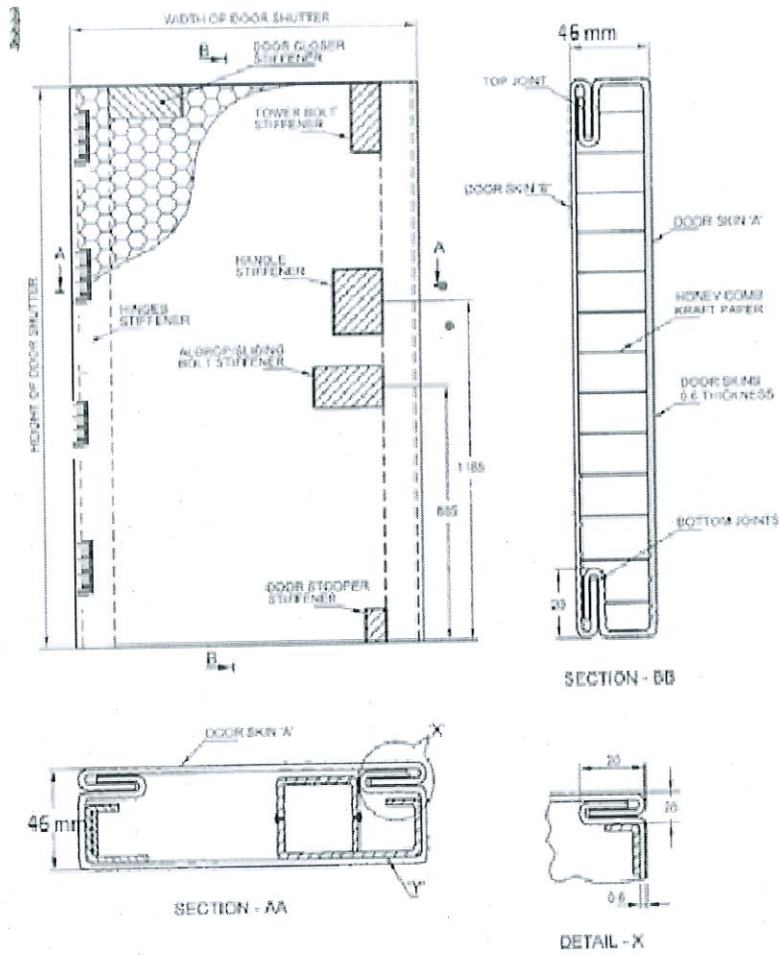

Firm



Handwritten notes: 40, 14/8, 21

Ch. Rajamarreddy
 Managing Director,
 APEWIDC, Vijayawada

Hinges

Lever Handle

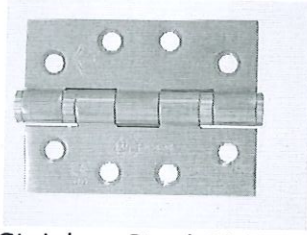

Stainless Steel 304

Heavy Duty Aldrop

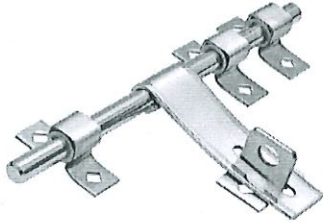

Powder Coated (MS) Tower Bolt

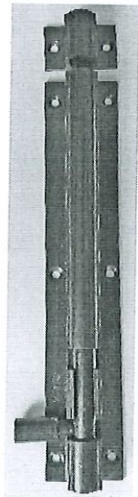

Grand Total of above Four (4) items including GST and all other taxes etc.,

Rs. 52,19,92,548/-

(Rupees Fifty Two Crores Nineteen Lakhs Nine Two Thousand Five Hundred Forty Eight Only)

Firm



Handwritten signature and date: 14/8/2021

Handwritten signature: Ch. Rajemareddy
Managing Director, APEWIDC, Vijayawada